

*Stereophonic*

# THE FISHER X-1000

# SERVICE

# MANUAL

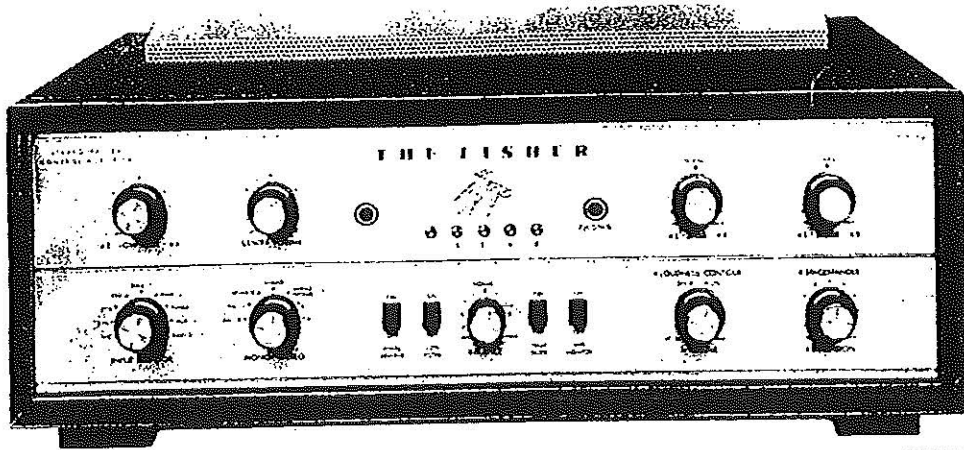

MODEL X-1000

CHASSIS SERIAL NUMBERS  
FROM 20001 TO 29999 INCLUSIVE

PRICE: \$1.00

FISHER RADIO CORPORATION • NEW YORK

CHASSIS SERIAL NUMBERS  
FROM 20001 TO 29999 INCLUSIVE

THE FISHER X-1000



## CAPACITORS

10% tolerance for all fixed capacitors, unless otherwise noted or marked GMV (guaranteed minimum value).

Symbol	Description	Part No.	Symbol	Description	Part No.
C1, 2	Ceramic, 100uf, GMV, N1500, 1000V	C50070-5	R13, 14	Composition, 4.7M	RC20BF475K
C3, 4	Mylar, .022uf, 250V	C50197-49	R15, 16	Dep. Carbon, 220K, 5%, 1/3 W	R33DC224J
C5, 6	Mylar, .047uf, 250V	C50197-52	R17, 18	Composition, 560K, 5%	RC20BF564J
C7, 8	Ceramic, 16uf, N75, 1000V	C50070-21	R19	Dep. Carbon, 100K, 5%, 1/3 W	R33DC104J
C9, 10	Ceramic, .005uf, 20%, 500V	C50089-1	R20	Potentiometer, Dual, 250K, Low Level	R50160-78
C11, 12	Electrolytic, 50uf, 3V	C50283-1	R21	Potentiometer, 25K, DC, Balance, Ch. B	R50103-2
C13	Ceramic, .0027uf, 1000V	C50072-17	R22	Dep. Carbon, 100K, 5%, 1/3 W	R33DC104J
C14	Mylar, .047uf, 400V	C50197-30	R23	Dep. Carbon, 470K, 5%, 1/3 W	R33DC474J
C15	Ceramic, .0027uf, 1000V	C50072-17	R24	Composition, 1.8M, 5%	RC20BF185J
C16, 17,			R25, 26	Dep. Carbon, 330K, 5%, 1/3 W	R33DC334J
18	Mylar, .047uf, 400V	C50197-30	R27	Composition, 1.8M, 5%	RC20BF185J
C19, 20	Ceramic, 24uf, 5%, N150, 1000V	C50070-8	R28	Dep. Carbon, 470K, 5%, 1/3 W	R33DC474J
C21, 22	Electrolytic, 50uf, 3V	C50283-1	R29, 30	Dep. Carbon, 120K, 5%, 1/3 W	R33DC124J
C23, 24	Ceramic, 820uf, 1000V	C50072-7	R31, 32	Dep. Carbon, 1.5K, 5%, 1/3 W	R33DC152J
C25, 26	Mylar, 1uf, 150V	C50197-78	R33	Dep. Carbon, 330K, 5%, 1/3 W	R33DC334J
C27, 28	Ceramic, 200uf, 1000V	C50072-22	R34, 35	Dep. Carbon, 120K, 5%, 1/3 W	R33DC124J
C29, 30	Mylar, .022uf, 250V	C50197-49	R36	Dep. Carbon, 1M, 5%, 1/3 W	R33DC105J
C31	Mylar, .047uf, 400V	C50197-30	R37, 38	Dep. Carbon, 470K, 5%, 1/3 W	R33DC474J
C32	Ceramic, 680uf, 1000V	C50072-2	R39	Composition, 2.2M, 5%, 1/3 W	RC20BF225J
C33	Mylar, .047uf, 400V	C50197-30	R40	Composition, 1.2M, 5%	RC20BF125J
C34	Ceramic, 680uf, 1000V	C50072-2	R41	Composition, 2.2M, 5%	RC20BF225J
C35, 36	Electrolytic, 50uf, 3V	C50283-1	R42	Composition, 1.2M, 5%	RC20BF125J
C37	Electrolytic, 4uf, 350V	C50283-4	R43	Dep. Carbon, 1M, 5%, 1/3 W	R33DC105J
C38	Electrolytic, 4 Section: A — 20uf, 400V B — 40uf, 450V C — 20uf, 400V D — 40uf, 450V	C50180-33	R44	Dep. Carbon, 220K, 5%, 1/3 W	R33DC224J
C39	Electrolytic, 1uf, 350V	C50283-3	R45, 46	Dep. Carbon, 1.5K, 5%, 1/3 W	R33DC152J
C40	Electrolytic, 50uf, 3V	C50283-1	R47	Composition, 1.5M, 5%	RC20BF155J
C41	Electrolytic, 1uf, 350V	C50283-3	R48	Dep. Carbon, 330K, 5%, 1/3 W	R33DC334J
C42	Electrolytic, 50uf, 3V	C50283-1	R49	Composition, 10M	RC20BF106K
C43, 44	Ceramic, 82uf, 5%, N1500, 1000V	C50070-33	R50	Composition, 1.5M, 5%	RC20BF155J
C45, 46,			R51	Dep. Carbon, 330K, 5%, 1/3 W	R33DC334J
47	Mylar, .1uf, 400V	C50197-32	R52	Composition, 10M	RC20BF106K
C48.	Mylar, .1uf, 250V	C50197-54	R53, 54	Dep. Carbon, 1.5K, 5%, 1/3 W	R33DC152J
C49	Mylar, .1uf, 400V	C50197-32	R55	Dep. Carbon, 150K, 5%, 1/3 W	R33DC154J
C50	Mylar, .1uf, 250V	C50197-54	R56	Dep. Carbon, 1M, 5%, 1/3 W	R33DC105J
			R57	Dep. Carbon, 150K, 5%, 1/3 W	R33DC154J
			R58	Dep. Carbon, 1M, 5%, 1/3 W	R33DC105J
			R59	Potentiometer, Dual, 250K Spacexpander, 1M Dimension	R50160-76
			R60	Dep. Carbon, 1.5K, 5%, 1/3 W	R33DC152J
			R61	Composition, 22K, 1W	RC30BF223K
			R62	Dep. Carbon, 1.5K, 5%, 1/3 W	R33DC152J
			R63	Composition, 22K, 1W	RC30BF223K
			R64, 65	Dep. Carbon, 470K, 5%, 1/3 W	R33DC474J
			R66	Dep. Carbon, 22K, 5%, 1/3 W	R33DC223J
			R67	Dep. Carbon, 10K, 5%, 1/3 W	R33DC103J
			R68	Dep. Carbon, 22K, 5%, 1/3 W	R33DC223J
			R69	Dep. Carbon, 10K, 5%, 1/3 W	R33DC103J
			R70	Potentiometer, Dual Vol., 100K	R841-132

C51	Electrolytic, 2 Section: A — 1000uf, 35V B — 1000uf, 35V	C50180-29
C52, 53, 54, 55	Mylar, .022uf, 250V	C50197-49
C56	Electrolytic, 3 Section: A — 30uf, 500V B — 30uf, 500V C — 30uf, 500V	C50180-31
C57	Electrolytic, 2 Section: A — 30uf, 500V B — 60uf, 500V	C50180-32
C58	Ceramic, 24uf, 5%, N150, 1000V	C50070-8
C59, 60	Electrolytic, 50uf, 70V	C50283-2
C61	Ceramic, 24uf, 5%, N150, 1000V	C50070-8
C62, 63	Ceramic, 18uf, 5%, N150, 1000V	C50070-30
C64	Electrolytic, 50uf, 70V	C50283-2
C65, 66, 67	Ceramic, 330uf, 1000V	C50072-1
C68, 69	Molded, .01uf, 20%, 600V	C2747
C70	Ceramic, 330uf, 1000V	C50072-1
C71, 72	Ceramic, 35uf, N75Q, 1000V	C50070-15
C73, 74	Ceramic, .01uf, 20%, 500V	C50089-3
C75	Ceramic, 330uf, 1000V	C50072-1

## RESISTORS AND POTENTIOMETERS

In ohms, 10% tolerance, 1/2 watt, unless otherwise noted. K=Kilohm, M=Megohm.

Symbol	Description	Part No.
R1, 2, 3, 4, 5, 6	Dep. Carbon, 100K, 5%, 1/2 W	R33DC104J
R7, 8	Potentiometer, 250K, Aux. Level Set	R50103-2
R9, 10	Dep. Carbon, 10K, 5%, 1/2 W	R33DC103J
R11, 12	Glass, 330K, 5%, 1W	R30G334J

R71	Potentiometer, 250K, 100K	R33DC473J
R72	Dep. Carbon, 47K, 5%, 1/2 W	R50160-75
R74	Potentiometer, Dual Bal., 300K	RC20BF330K
R75, 76	Composition, 33	RC20BF122K
R77, 78	Composition, 1.2K	R33DC154J
R79	Dep. Carbon, 150K, 5%, 1/2 W	RC20BF473K
R80, 81	Composition, 47K	R33DC224J
R82	Dep. Carbon, 220K, 5%, 1/2 W	RC20BF182J
R83	Composition, 1.8K, 5%	R33DC471J
R84	Dep. Carbon, 470, 5%, 1/2 W	RC20BF182J
R85	Composition, 1.8K, 5%	R33DC471J
R86, 87	Dep. Carbon, 470, 5%, 1/2 W	RC20BF223K
R88, 89	Composition, 22K	R33DC105J
R90, 91	Dep. Carbon, 1M, 5%, 1/2 W	R33DC223J
R92, 93	Dep. Carbon, 22K, 5%, 1/2 W	R33DC333J
R94, 95	Composition, 5.6K	RC20BF562K
R96	Dep. Carbon, 33K, 5%, 1/2 W	R33DC105J
R97, 98	Composition, 1M, 5%, 1/2 W	RC20BF682J
R99	Potentiometer, 25K, Phase Inverter, Adj. Ch. A.	R50103-2
R100	Dep. Carbon, 33K, 5%, 1/2 W	R33DC333J
R101	Potentiometer, 25K, Phase Inverter, Adj. Ch. B.	R50103-2
R102	Dep. Carbon, 33K, 5%, 1/2 W	R33DC333J
R103, 104	Composition, 2.7K, 1W	RC30BF272K
R105	Wirewound, 15, 5W	R719-106
R106, 107, 108, 109	Dep. Carbon, 1M, 5%, 1/2 W	R33DC105J
R110, 111	Glass, 750, 5W	RPG5W751K
R112, 113	Composition, 56K	RC20BF563K
R114, 115	Potentiometer, 10K, Bias Adj.	R50103-5
R116	Composition, 390K, 5%	RC20BF394J
R117	Potentiometer, 25K, DC, Balance, Ch. A.	R50103-2
R118	Composition, 390K, 5%	RC20BF394J
R119	Composition, 3.3K, 5%	RC20BF332J
R120, 121	Composition, 390K, 5%	RC20BF394J
R122	Composition, 3.3K, 5%	RC20BF332J
R123, 124	Composition, 68K	RC20BF683K

R125 Composition, 1K  
 R126, 127 Composition, 68K  
 R128 Composition, 1K  
 R129, 130 Composition, 4.7K  
 R131, 132 Composition, 220  
 R133, 134 Wirewound, 10, .5W  
 R135 Potentiometer, Dual, 1M, Bass  
 R136 Potentiometer, Dual, 500K, Treble  
 R137 Dep. Carbon, 47K, 5%, 1/2 W  
 R138 Dep. Carbon, 1M, 5%, 1/2 W  
 R139, 140 Composition, 390  
 R141 Composition, 4.7K  
 R142, 143 Composition, 2.2K  
 144, 145,  
 146, 147,  
 148, 149 Wire Wound, 7W, 27  
 R150, 151 Composition, 330, 1W  
 R152, 153 Dep. Carbon, 1M, 5%, 1/2 W  
 R154, 155 Glass, 2.7K, 5%, 1/2 W  
 R156, 157 Composition, 1K

RC20BF102K  
 RC20BF683K  
 RC20BF102K  
 RC20BF472K  
 RC20BF221K  
 R779-103  
 R50160-79  
 R50160-77  
 R33DC473J  
 R33DC105J  
 RC20BF391K  
 RC20BF472K  
 RC20BF222K  
  
 R841-109  
 RC30BF331K  
 R33DC105J  
 R30G272J  
 RC20BF102K

### MISCELLANEOUS

Symbol	Description	Part No.
FI	Fuse, 5 Amp., Slo-Blo	F841-133
11, 2, 3, 4, 5	Pilot Light, #47	150009-1

PC1	Printed Circuit, 3 3/4 Tape EQ.	PC50187-7
PC2	Printed Circuit, Col. LP. EQ.	PC50187-6
PC3	Printed Circuit, RIAA & Tape EQ.	PC50187-3
PC4	Printed Circuit, 3 3/4 Tape EQ.	PC50187-7
PC5	Printed Circuit, Col. LP. EQ.	PC50187-6
PC6	Printed Circuit, RIAA & Tape EQ.	PC50187-3
PC7, 8	Printed Circuit, H. Freq. Filter	PC50187-5
PC9, 10	Printed Circuit, Tone Control	PC657-140
S1	Switch	R841-123
S2	Switch	R841-136
S3, 4, 5, 6	Switch, Slide	S50200-5
S7	Switch, Loudness, Contour	Part of R70
S8	Switch, Center Ch., Power	R841-137
S9	Switch, Power	Part of R70
T1	Transformer, Output	T841-116-2
T2	Transformer, Output	T841-116-1
T3	Transformer, Power	T841-115
CR1, 2	Diode, Silicon, SD91	SR851-121
CR3	Senelium Rect.	SR50253-5
CR4, 5, 6, 7	Diode, Silicon, SD95A	SR806-126
—	Dress Panel	AS841-127
—	Tube Shield	E3287
—	Jewel, Red	150162-1
—	Jewel, Yellow	150162-2
—	Jewel, Green	150162-4
—	Fuse Holder *	X563-151

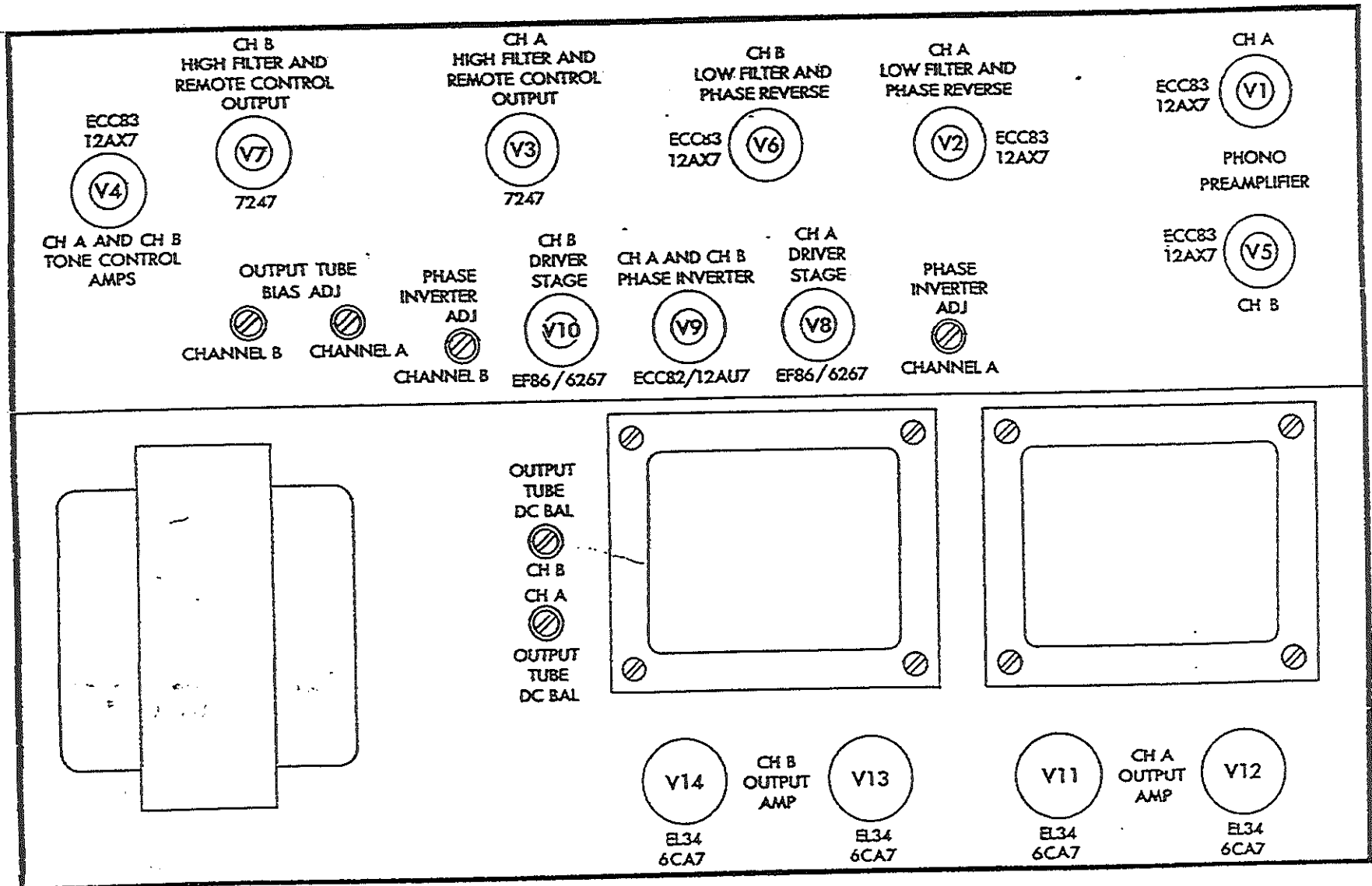

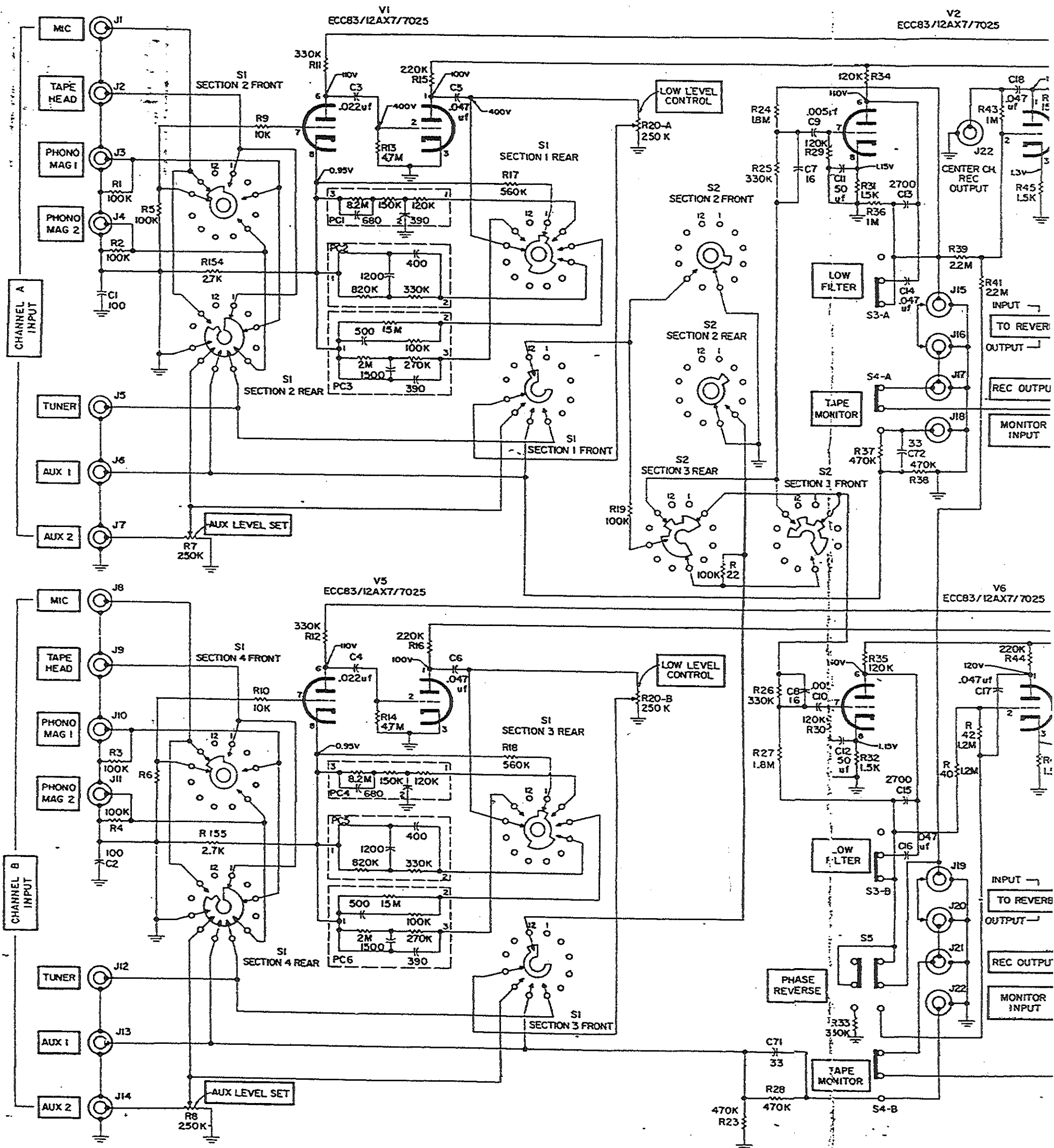

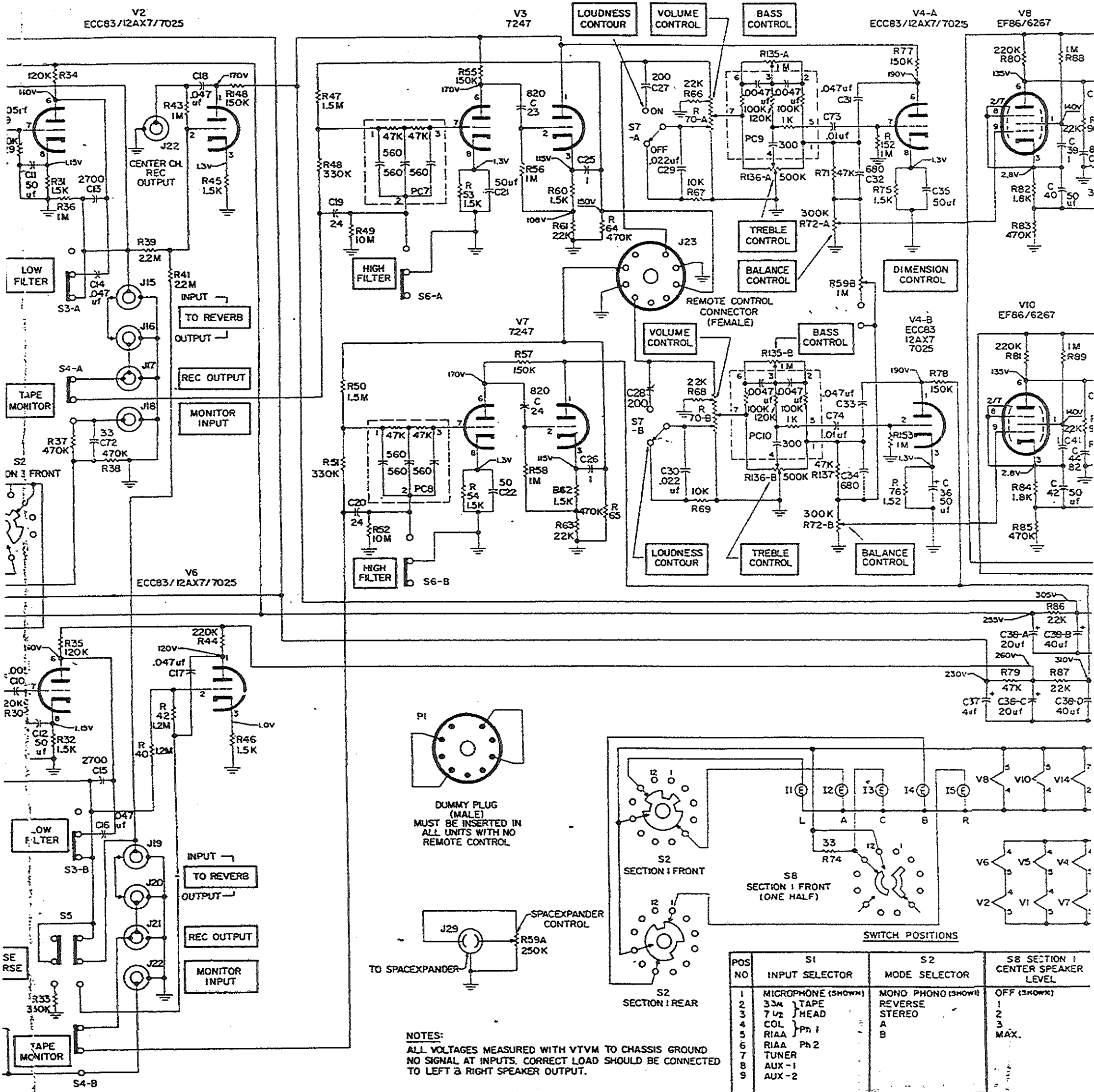

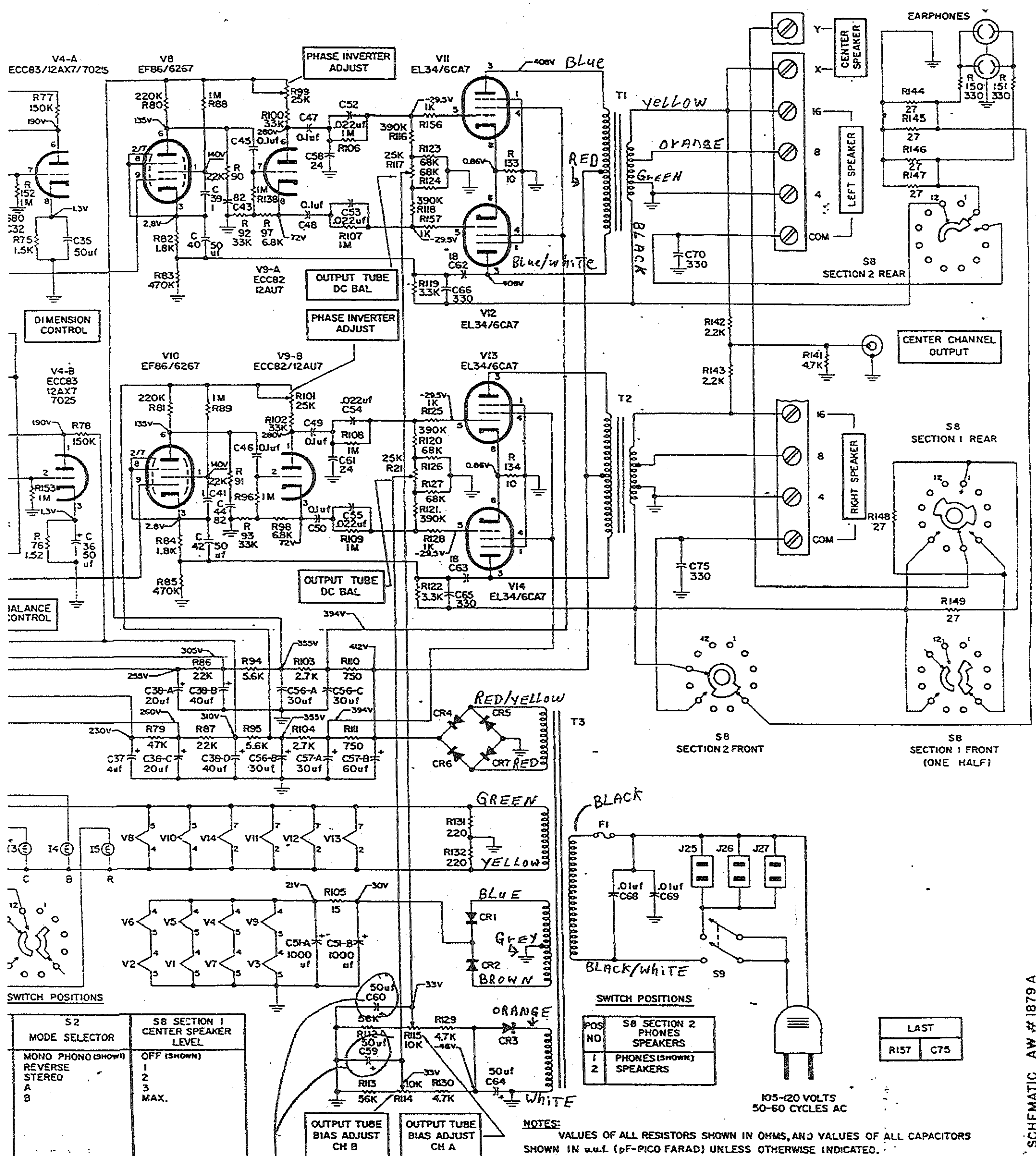

S2 MODE SELECTOR	S8 SECTION 1 CENTER SPEAKER LEVEL
MONO PHONO (SHOWN)	OFF (SHOWN)
1	1
REVERSE	2
STEREO	3
A	MAX.
B	

POS NO	S8 SECTION 2 PHONES SPEAKERS
1	PHONES (SHOWN)
2	SPEAKERS

LAST	
R157	C75

NOTES: VALUES OF ALL RESISTORS SHOWN IN OHMS, AND VALUES OF ALL CAPACITORS SHOWN IN  $\mu\text{f}$ . (pF-PICO FARAD) UNLESS OTHERWISE INDICATED.